

**DIGITAL-WERKSTATT-MESSSCHIEBER MIT SPITZEN**  
*DIGITAL CONTROL CALIPER WITH POINTS*

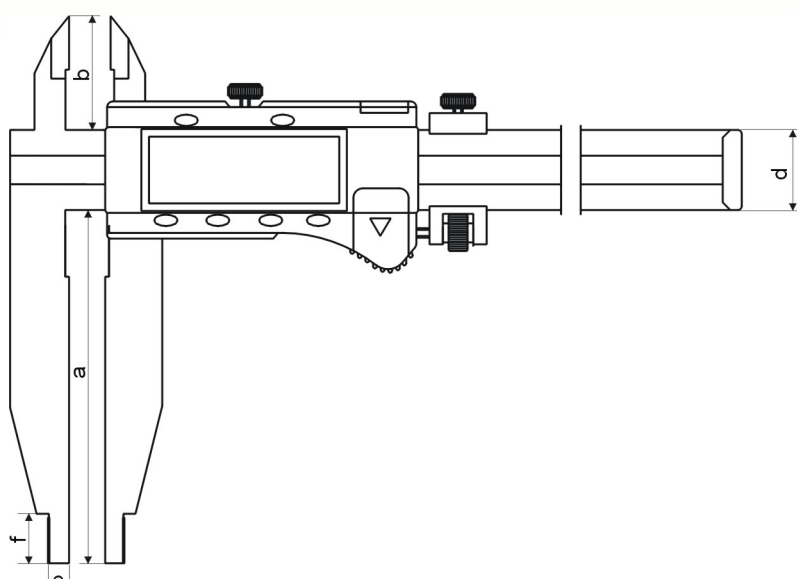

- aus rostfreiem Stahl, ganz gehärtet
- mit Feineinstellung
- Genauigkeit nach Werksnorm
- Anzeige: 0,01 mm oder 0,0005"
- im Behältnis/Kasten

- *made of stainless steel, hardened*
- *with fine adjustment*
- *accuracy subject to manufacture standard*
- *reading: 0,01 mm or 0,0005"*
- *in case/box*

- Messsystem mit 3 V
- mit Ein/Aus-, Null-, Unit- und Hold-Taste
- Datenausgang (RB 5)

- *Measuring system with 3 V*
- *with on/off, zero, unit and hold button*
- *Data output (RB 5)*

Art.-Nr. <i>Item no.</i>	Messbereich <i>Range mm</i>	Schnabellänge <i>Jaws a mm</i>	Genauigkeit <i>Accuracy mm</i>	b <i>mm</i>	d <i>mm</i>	e <i>mm</i>	f <i>mm</i>	kg
<b>217.063.N</b>	300	60	0,03	38	17	5	12	0,3
<b>217.043.N</b>	300	90	0,03	38	17	5	12	0,4