

MAGNET-MESSSTATIV MIT ZENTRALKLEMMUNG
MAGNETIC DIAL SUPPORTS WITH CENTRAL CLAMPING

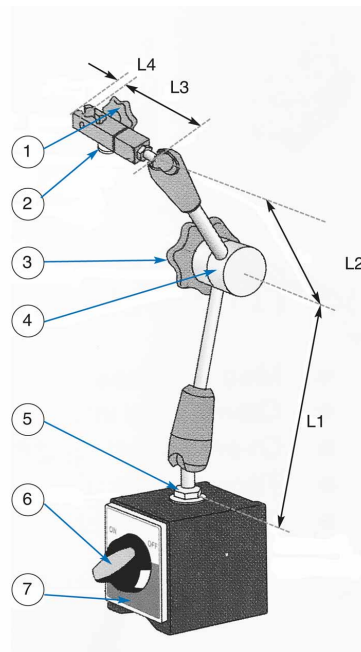

- mit mechanischer Zentralklemmung
- mit Feineinstellung
- für Messuhr mit 8 mm Aufnahme
- mit Ein/Aus-Schalter und Prismenfuß

- *with central mechanical clamping*
- *fine adjustment*
- *for dials 8 mm shank*
- *with on/off switch and prismatic base*



1. Messuhr-Befestigungsschraube
2. Feineinstellung
3. Zentralklemmung
4. Gelenke
5. Befestigungsschraube
6. Schalter für Magnet
7. Magnetfuß

1. *Dial gauge clamping screw*
2. *fine adjustment*
3. *Tightening knob*
4. *cylinder joints*
5. *tightening screw*
6. *switch*
7. *magnetic base*

Art.-Nr. <i>Item no.</i>	Gesamthöhe <i>Total height</i> mm	L1 <i>mm</i>	L2 <i>mm</i>	L3 <i>mm</i>	L4 <i>mm</i>	Fuß <i>Base (LxBxH)</i> mm	Magnetkraft <i>Magnet force</i> kg	Euro/St. <i>Euro/Pc.</i>
208.109.1	400	160	125	46	14	59 x 50 x 55, M8	60	45,10
208.109.2	400	160	125	46	14	61 x 50 x 55, M8	80	52,20
208.109.G	345	160	125	46	14	-	-	36,40