

DREIPUNKT-INNEN-MESSSCHRAUBEN, DIN 863

THREE POINT INTERNAL MICROMETER, DIN 863

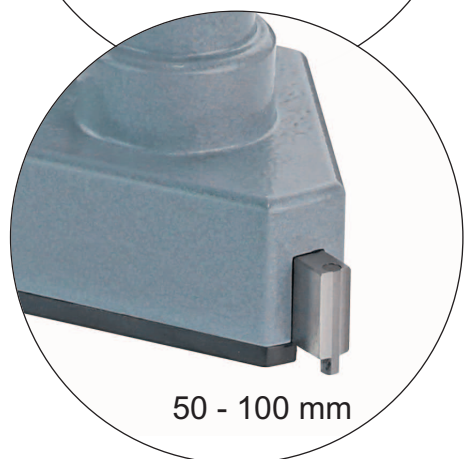

- geeignet zur Messung von Sacklochbohrungen
- mit Hartmetall-Messflächen ab 12 mm
- Skala- und Nonius mattverchromt
- mit Einstellung und Verlängerung im Behältnis/Kasten

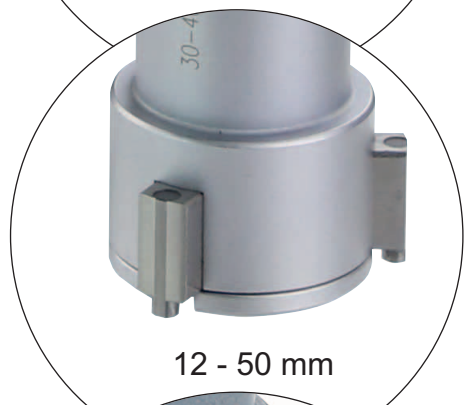
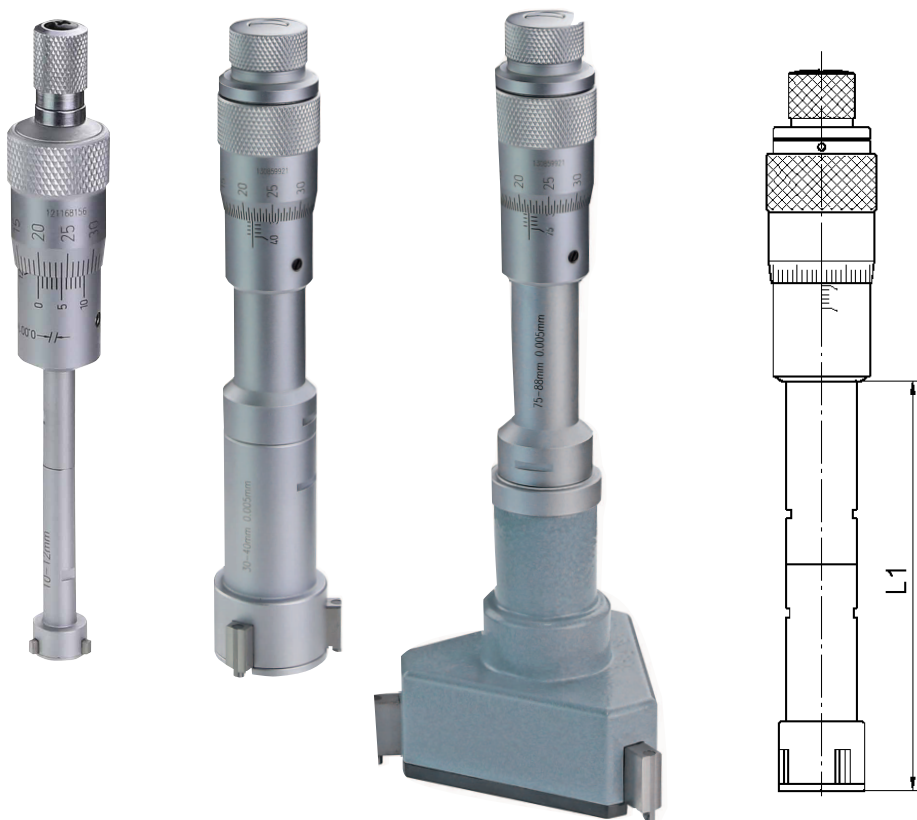
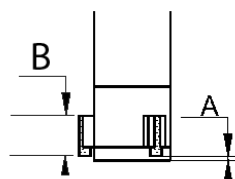

- *for blind hole*
- *with carbide measuring faces from 12 mm*
- *satin chrome finished*
- *with setting gauge and extension in case/box*

Art.-Nr. <i>Item no.</i>	Messbereich <i>Range mm</i>	Einstellung <i>Standard mm</i>	Verlängerung <i>Extention mm</i>	A <i>mm</i>	B <i>mm</i>	L1 <i>mm</i>	Ablesung <i>Reading mm</i>	Genauigkeit* <i>Accuracy* μm</i>
312.130	6 - 8	8	100 x ø 5,7	0,5	2,5	55	0,001	0,004
312.131	8 - 10	8	100 x ø 5,7	0,5	2,5	55	0,001	0,004
312.132	10 - 12	10	100 x ø 5,7	0,5	2,5	55	0,001	0,004
312.133	12 - 16	12	150 x ø 11,7	0,5	6,3	80	0,005	0,005
312.134	16 - 20	16	150 x ø 11,7	0,5	6,3	80	0,005	0,005
312.135	20 - 25	25	150 x ø 16,0	0,5	8,2	90	0,005	0,005
312.136	25 - 30	25	150 x ø 16,0	0,5	8,2	90	0,005	0,005
312.137	30 - 40	30	150 x ø 23,4	0,5	13,8	97	0,005	0,005
312.138	40 - 50	40	150 x ø 23,4	0,5	13,8	97	0,005	0,005
312.160	50 - 63	50	150 x ø 23,4	0,5	17,7	114	0,005	0,005
312.161	62 - 75	62	150 x ø 23,4	0,5	17,7	114	0,005	0,005
312.162	75 - 88	87	150 x ø 23,4	0,5	17,7	114	0,005	0,005
312.163	87 - 100	87	150 x ø 23,4	0,5	17,7	114	0,005	0,005