

FÜHLHEBELMESSGERÄT, HORIZONTAL, ABLESUNG 0,002 mm

UNIVERSAL TEST INDICATOR, HORIZONTAL, READING 0.002 mm

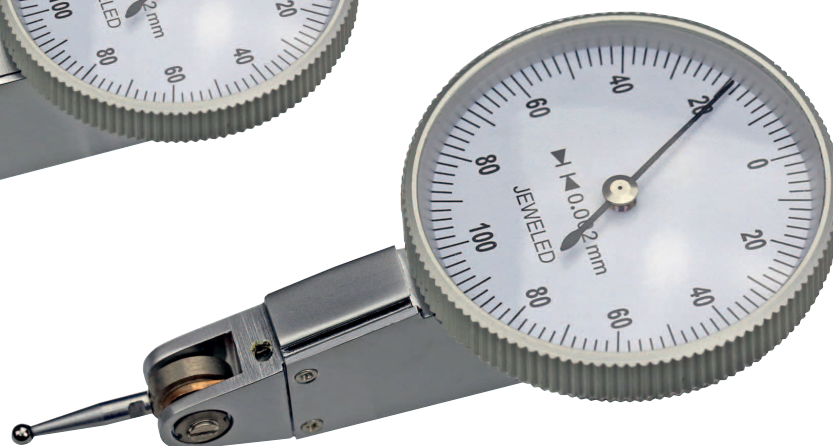

208.001



208.001.2

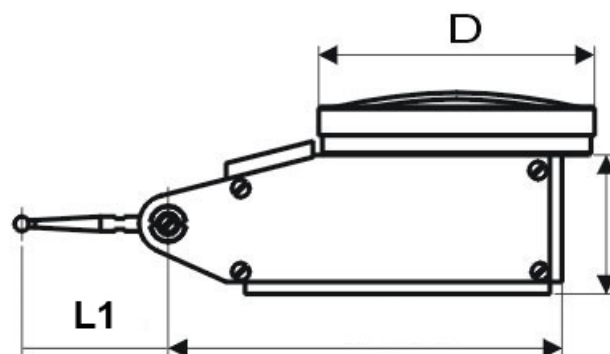
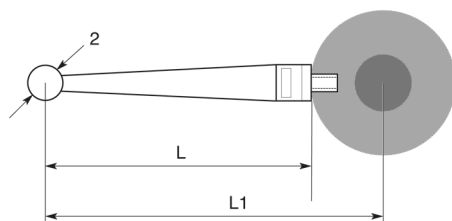

- Genauigkeit nach DIN 2270, stoßgeschützt
- mit HM bestücktem Messeinsatz Ø 2 mm
- automatische Umkehr der Messrichtung
- mit Schwalbenschwanzführungen für Einspannschaft Ø 6 mm und Ø 8 mm (inkl.)
- im Behältnis/Kasten

- *accuracy DIN 2270*
- *carbide tipped probe Ø 2 mm*
- *shock proof, automatically inversion of measuring direction*
- *with 2 connectors Ø 6 mm and Ø 8 mm*
- *in case/box*

Art.-Nr. <i>Item no.</i>	Messbereich <i>Range mm</i>	Ablesung <i>Reading mm</i>	Bezifferung <i>Scale mm</i>	D <i>mm</i>	L <i>mm</i>	L1 <i>mm</i>
208.001	0,2	0,002	0 - 100 - 0	32	13,5	17
208.001.2	0,2	0,002	0 - 100 - 0	40	13,5	17